

# Freeway

Распределители 4/3, 4/2, 3/2, прямого управления типа FW

Ном. разм. 06, 10

до 31,5 Мпа

до 400 л/мин

Переключаемые электромагнитами золотниковые распределители типа FW управляют пуском, остановкой и направлением движения потока жидкости.



FW      03      3C2      DC24      Z5L      50

серия

50

60

70

Z4- без светоиндикации

Z5L- с светоиндикацией

D12=12VDC постоянный ток

D24=24VDC постоянный ток

B110=110VAC постоянный ток

B220=220VAC постоянный ток

A110=110VAC переменный ток

A220=220VAC переменный ток

схема (стр. 2)











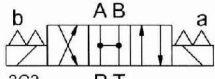
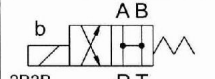
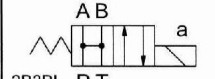
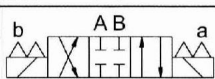
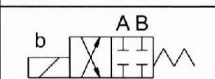
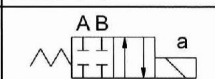

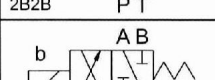
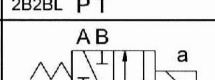
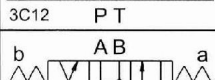
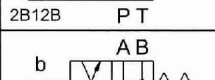
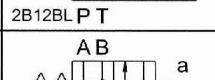
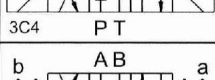
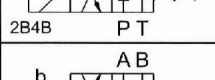
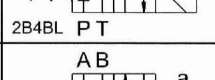



02=ДУ06





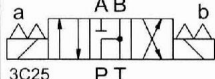
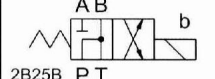
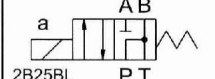

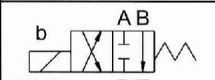
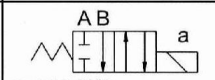
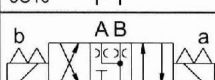
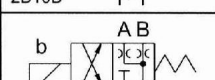



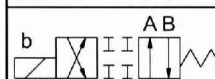

03=ДУ10

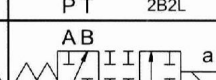
FW- распределитель с электроуправлением

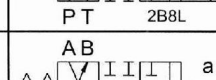
Модель		FW 02	FW 03
Макс. давление, Мпа	Р, В, А	31,5	31,5
	порт Т	16	16
Макс. расход, л/мин		35	63
Макс. темпер., °С		-20~70	
Вязкость, мм2/с		2,8~380	
4/2, кг		1,7	4,7
4/3, кг		2,5	6
Вольтаж		DC	AC
		12, 24	110, 220
потребляемая мощность		35	
			65
частота переключения		15000	7200

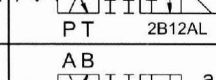
## Условные изображения

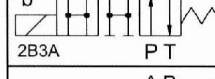
 3C3 PT	 2B3B PT	 2B3BL PT
 3C2 PT	 2B2B PT	 2B2BL PT
 3C12 PT	 2B12B PT	 2B12BL PT
 3C4 PT	 2B4B PT	 2B4BL PT
 3C9 PT	 2B9B PT	 2B9BL PT
 3C5 PT	 2B5B PT	 2B5BL PT
 3C60 PT	 2B60B PT	 2B60BL PT
 3C25 PT	 2B25B PT	 2B25BL PT
 3C10 PT	 2B10B PT	 2B10BL PT
 3C40 PT	 2B40B PT	 2B40BL PT
 3C11 PT	 2B11B PT	 2B11BL PT

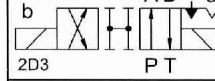
 2B3 PT	 PT 2B3L
 2B2 PT	 PT 2B2L
 2B8 PT	 PT 2B8L
 2B12A PT	 PT 2B12AL
 2B2A PT	 PT 2B2AL
 2B3A PT	 PT 2B3AL
 2D3 PT	 2D8 PT
 2D2 PT	

## Размеры

### FW-02

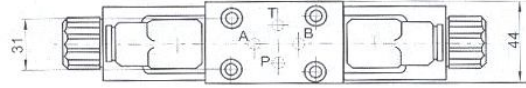
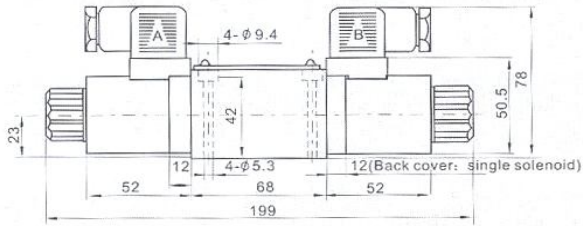

### FW-03

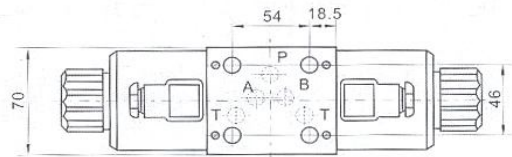
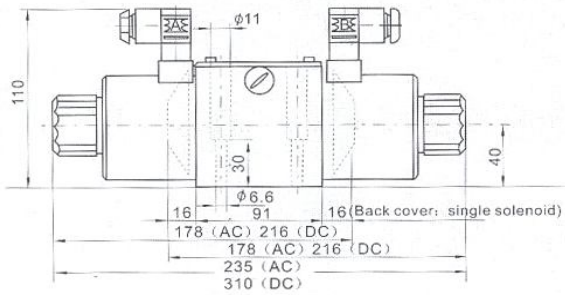

## Размеры плиты

### FW-02

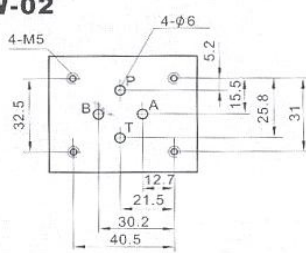

### FW-03

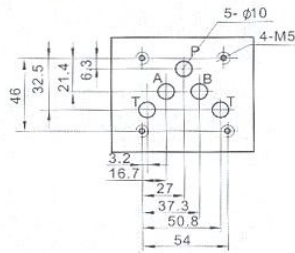

	FW-02	FW-03
Комплект уплотнений:	8,73x1,78	11,91x2,62
Комплект болтов:	4-M5x50-12,9	4-M6x50-12,9

## Комплектующие

Электромагниты применяются для управления золотником гидрораспределителя.

<b>FOR FW</b>	<b>03</b>	<b>DC24</b>	<b>50</b>
		серия	
		D12=12VDC постоянный ток	
		D24=24VDC постоянный ток	
		B110=110VAC постоянный ток	
		B220=220VAC постоянный ток	
	02=ДУ06		
	03=ДУ10		

FOR FW катушка

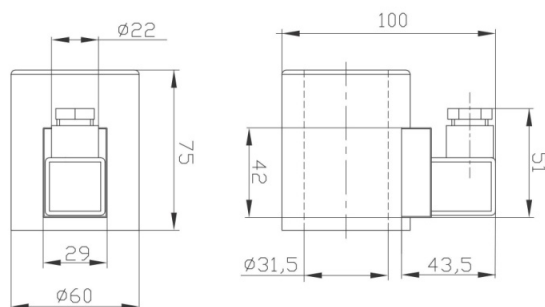
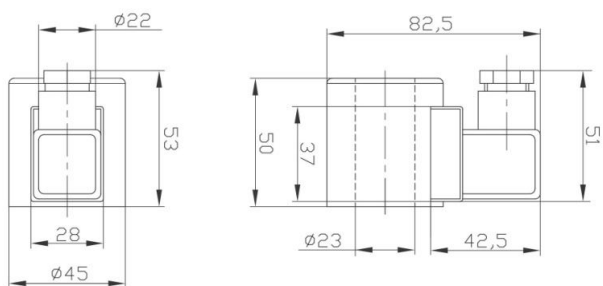

### Данные для заказа

FOR FW-02 DC12
FOR FW-02 DC12
FOR FW-02 B110
FOR FW-02 B220

### Данные для заказа

FOR FW-03 DC12
FOR FW-03 DC12
FOR FW-03 B110
FOR FW-03 B220