

Şanzıman No / Gearbox No

ZF 16S 251-221-151-150-130 ZF S5/AK/ 6S-120-111-110-92, GP ZF S5/K/6S-90-80-70-66-65-55-50 42-36-35/ZF 9S 75/ 9S109/16S10 9/ ZF AK 6 80/AK 6 90 /S6 80/S690, ZF 6S-1000: 694 rpm; ZF9S-1310: 1273 rpm, ZF 16S-151 T0 / 13.8-0.84: 1192/1428 rpm, ZF 16S-1820: 1192/1428 rpm, ZF 16S-2220 TD: 1009/1192 rpm, ZF 16S-2220 T0 192/1428 rpm, ZF 16S-2520: 1192/1428 rp

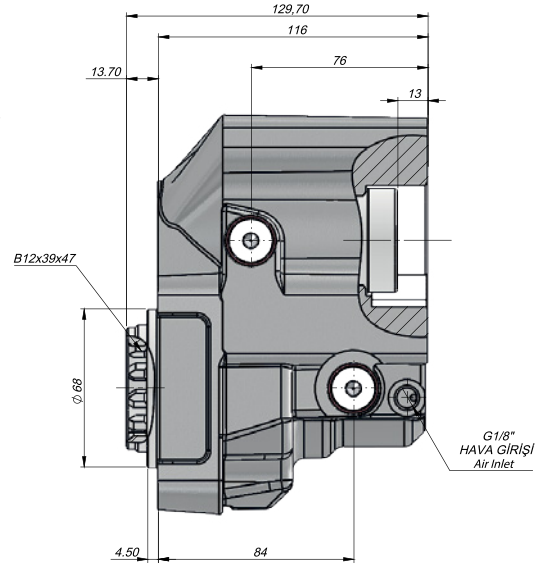
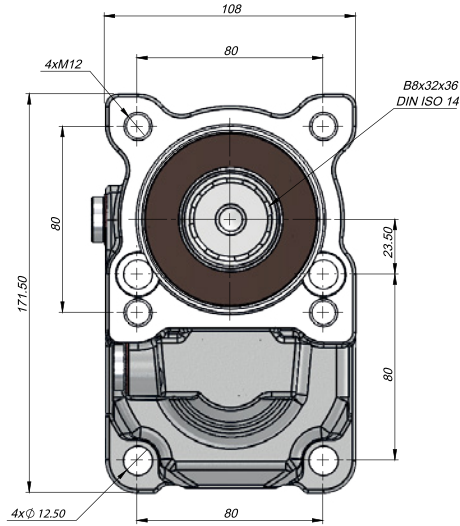

Kod Code	Havalı Çalışma Basıncı Pneumatical Working Pressure	Montaj Flanş Mounting Flange	Çıkış Out	Kontrol Sistemi Control System	Çevrim Oranı Ratio	Çıkış Hızı Output Speed	Dönüş Yönü Direction Of Rotation
	(Bar)					(Nm) Tork	
PT2S131WS	7-12	Arka Rear	Arka Rear	Havalı Pneumatic	1:1,31	250	Sol Left
PT2S131SW							

*(SW) - Switch

(WS) - Without Switch