

REV	REV TARİHİ	AÇIKLAMA	RESİM NO
-----	------------	----------	----------

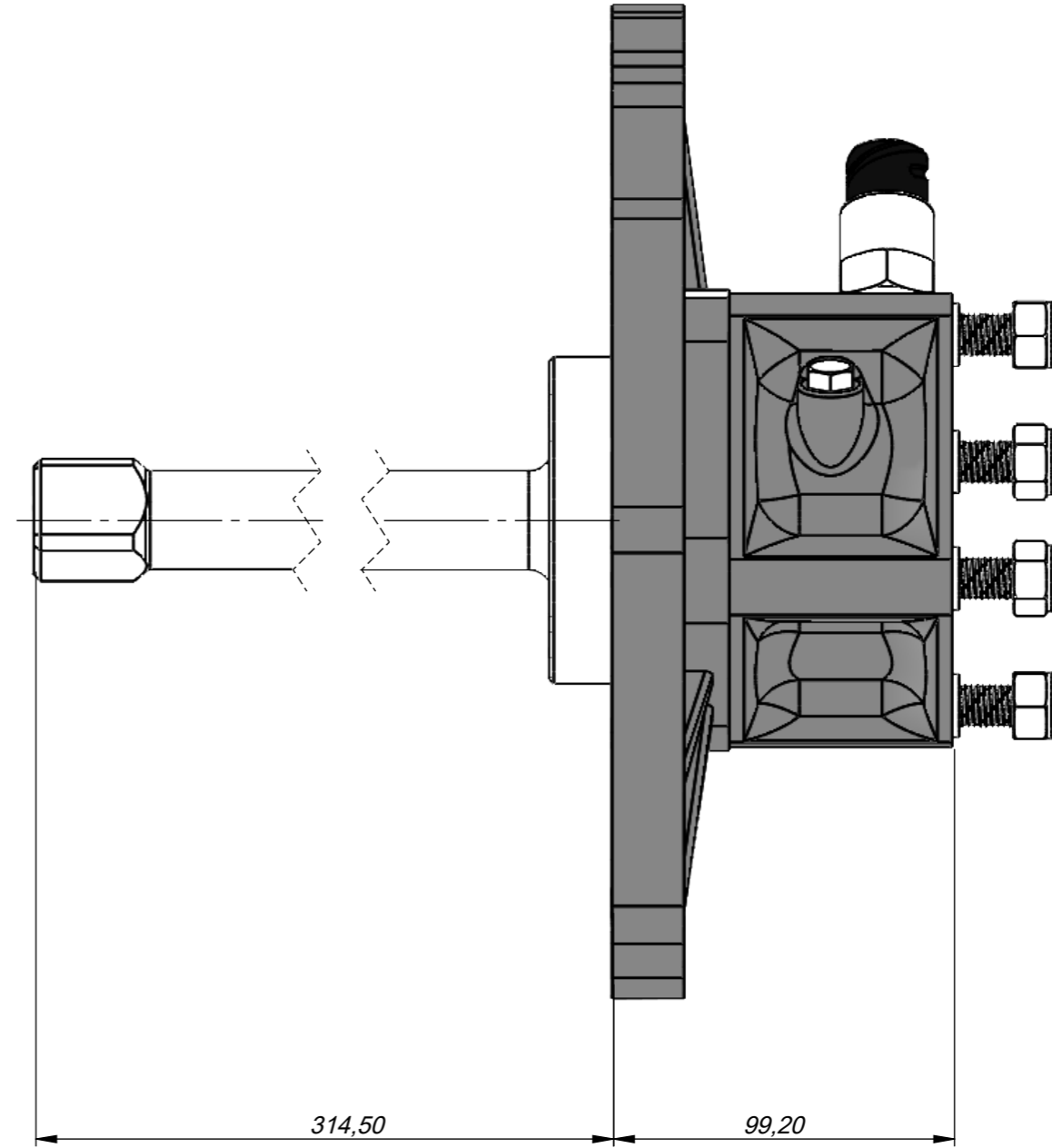
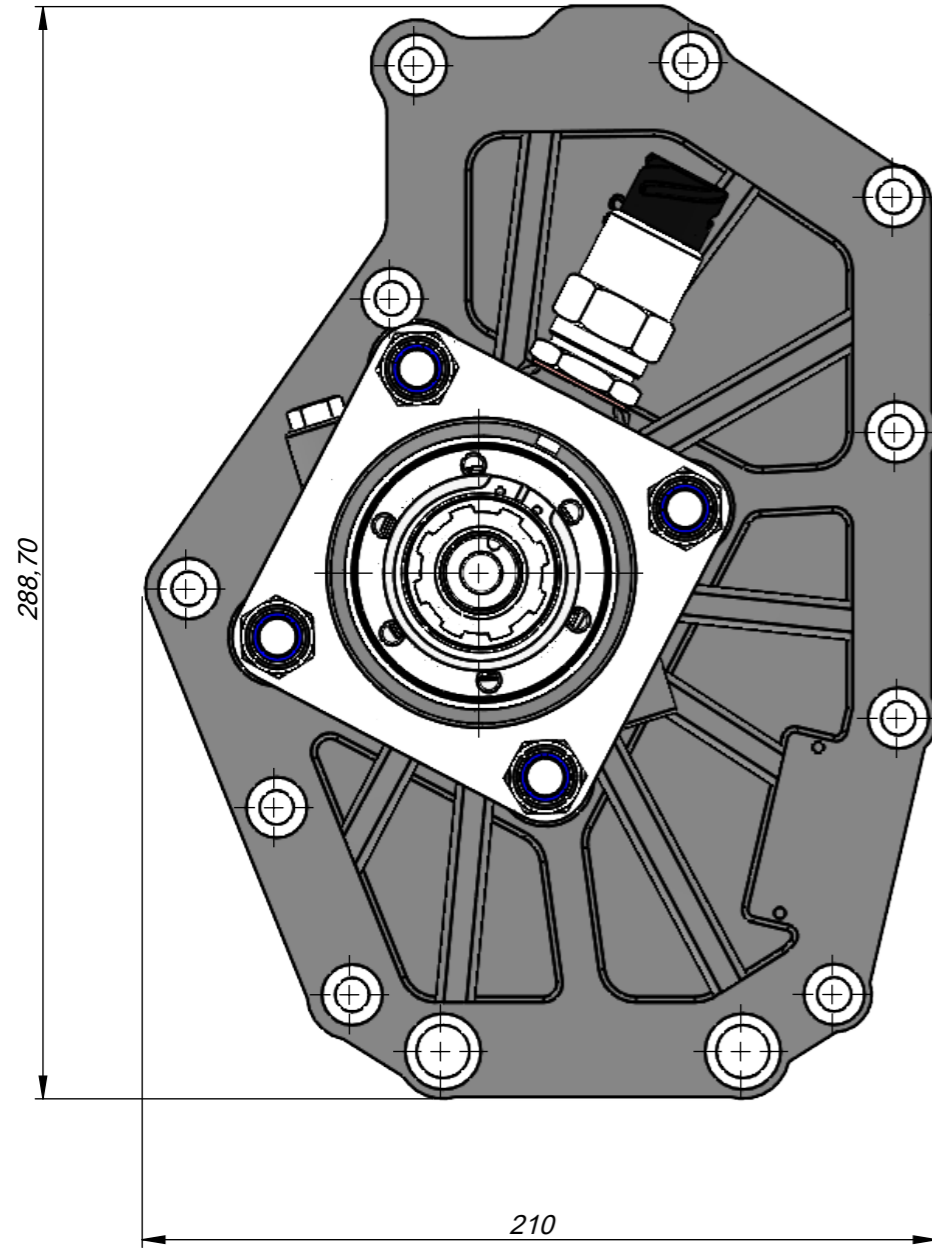

Kod Code	Şanzuman Modeli Gear Box Model	Havalı Çalışma Basıncı Pneumatical Working Pressure	Kontrol Sistemi Control System	Çevrim Oranı Ratio	Çıkış Tork Outlet Torque	Güç / Power	Çıkış Hızı Output Speed	AD-SOYAD	TARİH	İMZA
								ÇİZEN	KONTROL	ONAY
		(Bar)			(Nm)	(Kw)1000 dev/dak	dev/dak	A.AKGÖZ	17.10.2023	
			Havalı Pneumatic	1:1	490	24 Kw	1000	M.SAĞLAM	17.10.2023	
								F.KAZEL	17.10.2023	
GBSCG33CM332/PT12FAS12	16S-130-160-190	7-12								

KAZEL
HYDRAULIC EQUIPMENTS